

Solstice[®] SSB

Installation Guide

Model SSB2512LNU

Model SSB2509LNU

PM00476 Revision 4

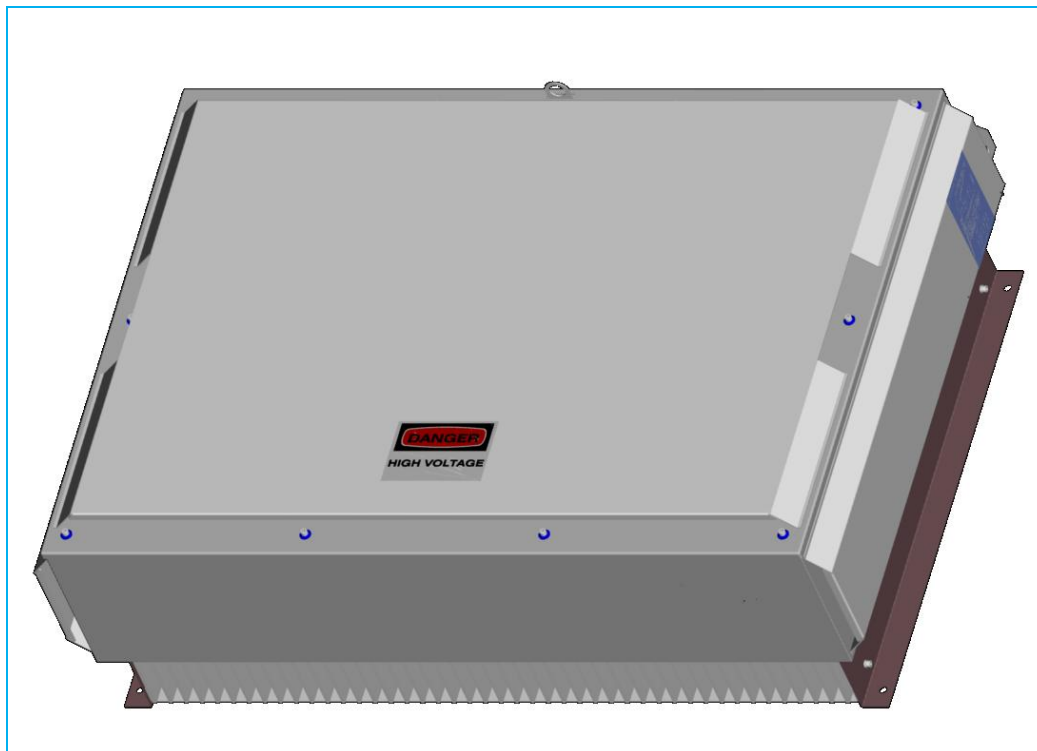

Satcon Technology Corporation

27 Drydock Avenue, Boston, MA 02210, U.S.A.
Tel: 617.897.2400 | Fax: 617.897.2401 | www.satcon.com

© 2007–2010 by Satcon.

This document is the confidential and proprietary information of Satcon. No part of this document may be photocopied, reproduced, stored in a retrieval system, or transmitted in any form or by any means whether electronic, mechanical, or otherwise without prior written permission.

Satcon reserves the right to change details in this publication without notice.

PV View® Plus is the registered trademark of Satcon. Solstice® and Edge™ MPPT is a trademark of Satcon. Other product names and/or organization names mentioned may be trademarks and/or registered trademarks of their respective companies.

Publication Number

PM00476

Date and Revision

REV.	ECO	DATE	AUTHOR	APPR.	COMMENT
0	9404	Nov 25, 2009	A.Pamp S.Nichols G. Mounsey	S.N.	Original Release
1	9611	Jan 22, 2010	A. Pamp S. Nichols G. Mounsey	H.K.	Updated to include changes to the SSB
2	9796	Mar 26, 2010	M. Lee J. Andrade	M.L.	No changes made to the manual at this revision. Revision changed to 2 due to Avante data entry error.
3	9751	Apr 26, 2010	A. Karlgren S. Nichols J. Andrade	S.N.	Added Model SSB2509LNU Updated Single Line Drawing SD00210 (SSB2512LNU)
4	10032	Jun 17, 2010	S. Nichols J. Andrade		Added RS485 Modbus Communications

Table of Contents

About This Guide	ii
Purpose	ii
Who Should Read this Guide	ii
How the Guide is Organized	ii
Reference Manuals	ii
IMPORTANT SAFETY INSTRUCTIONS	iv
Chapter 1 Product Information	1
About this Chapter.....	1
Solstice System Overview.....	2
Solstice SSB Unit	3
Chapter 2 Installation Information	6
About this Chapter.....	6
Step 1 – Plan and Install Conduits	7
Conduit Penetrations.....	7
Enclosure Wall Thickness	7
Preferred Practices.....	7
Step 2 – Mount Enclosure	9
Step 3 – Connect Electrical Conductors	11
Appendix	13
Single Line Drawings.....	13
Enclosure Layout Drawing	13

List of Figures

Figure 1 Solstice System Overview	2
Figure 2 Solstice SSB Unit.....	3
Figure 3 SSB Bottom View.....	8
Figure 4 Typical Conduit Connections	8
Figure 5 Solstice SSB Dimensions	10
Figure 6 Solstice SSB Mounting Diagram.....	10
Figure 7 Customer Wiring Diagram	11

List of Tables

Table 1 Ratings and Specifications for Solstice SSB (Sheet 1 of 2).....	4
Table 2 Torque Ratings.....	12

About This Guide

Purpose

This guide is intended for use by personnel to become familiar with the operation and maintenance requirements of the Solstice SSB unit.

Who Should Read this Guide

This guide is intended for users who need to:

- Install the Solstice SSB unit.

How the Guide is Organized

This guide contains the following two chapters:

- Chapter 1 Product Information: This chapter provides general information about the Solstice system and the Solstice SSB unit.
- Chapter 2 Installation Information: This chapter explains how to install, operate, and maintain the system.

Reference Manuals

The following manual is available and will be required for installing the Solstice SubCombiner:

- PM00477 (Solstice® SDMS-100 Inverter “*Installation, Operation and Maintenance Guide*”)

Conventions Used

**WARNING**

Warnings tell you about conditions or actions that could result in personal injury or death. A qualifier (e.g. Hazardous Voltage) may follow the warning title.

**WARNING– SHOCK HAZARD**

Represents an electrical hazard alert. This symbol tells you that DANGEROUS HIGH VOLTAGES are present inside the enclosure of this product.

**CAUTION**

Cautions tell you about conditions or actions that could result in damage to the inverter or other equipment. A qualifier (e.g. Inverter Damage) may follow the warning title.

**NOTE**

Notes tell you about things which are important for you to know but not as serious as cautions or warnings.

IMPORTANT SAFETY INSTRUCTIONS

SAVE THESE INSTRUCTIONS

This manual contains important instructions for Solstice SSB units SSB2512LNU and SSB2509LNU that shall be followed during installation and maintenance of the inverter.

WARNING



The Solstice inverter system presents a **SHOCK HAZARD**. Read and keep this *Installation Guide* for future reference. Before installing this inverter, read all instructions, cautionary markings and other appropriate sections of this guide. Failure to follow these warnings could result in severe shock or even death. Exercise extreme caution at all times to prevent possible accidents.

WARNING



These instructions are not meant to cover every safety eventuality nor to replace any local or site specific safety procedures. The information in this section is intended as a supplement to local or site specific procedures. Satcon does not assume responsibility for the compliance or noncompliance to any code, national, local or otherwise for the proper installation of the Solstice inverter or associated equipment supplied.

A potential for personal injury and/or equipment damage exists if electrical codes and these instructions are not followed.

DANGER



This Solstice inverter contains **LETHAL VOLTAGES**. Only authorized service personnel should perform all repairs and service. There are no user serviceable parts inside this inverter.

Chapter 1 Product Information

About this Chapter

This chapter provides a brief introduction about the Solstice system and Solstice SSB unit, including the specifications regarding the SSB unit.

Solstice System Overview

The Solstice inverter is part of the Satcon Solstice distributed energy management system. This system provides granular control over every component in the array, from a single string, to the inverter, to power delivered to the grid.

The Solstice system (Figure 1) contains the following primary components:

- Solstice SSB;
- Solstice Inverter;
- Optional ancillary inputs from weather stations, power meters, etc.

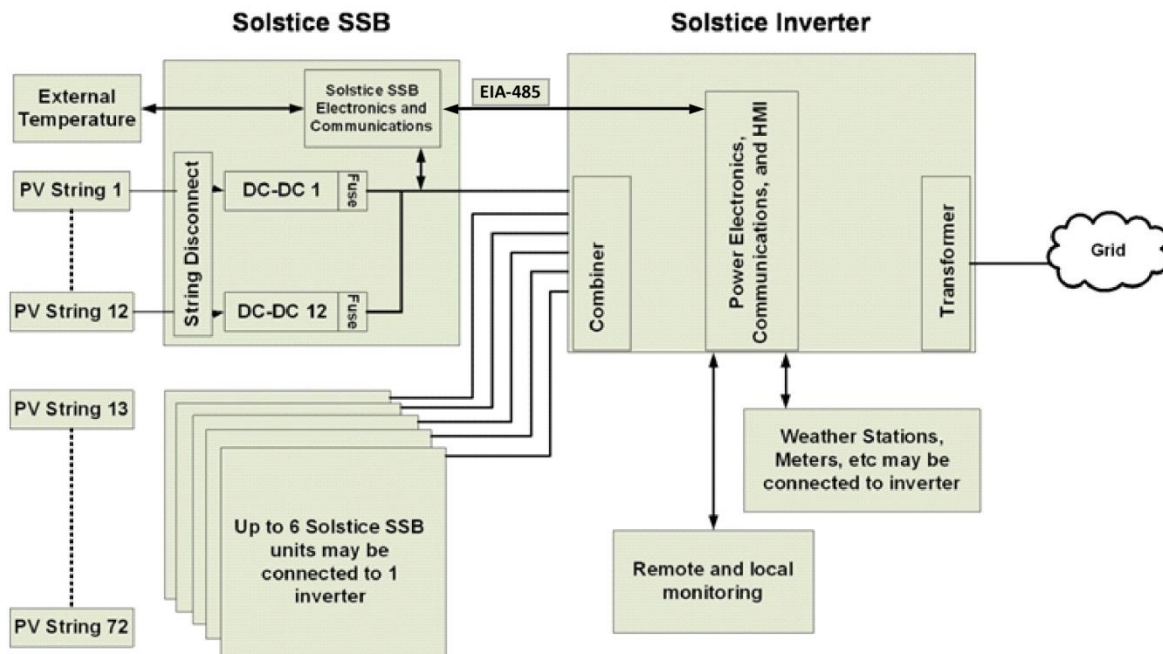

Figure 1 Solstice System Overview

The PV array is connected to the Solstice inverter through the Solstice SSB. Up to 12 PV strings can be connected to each SSB unit (SSB2512 model, or up to nine PV strings for the SSB2509 model) and as many as six SSB units can be connected to one Solstice 100kW inverter. Maximum power point tracking (MPPT) is performed within the Solstice SSB unit.

The Solstice inverter processes all data and power inputs from the Solstice SSB unit(s), as well as data from such ancillary devices as weather stations, power meters, and so on. The inverter also provides the power electronics for the system, as well as external communications (for local and remote communication). Local operator control is accomplished through the Human Machine Interface (HMI). The AC power output is conditioned through an integrated transformer.

Solstice SSB Unit

This model of the Solstice SSB unit is designed for 600 V, UL negative grounded systems, with a rated maximum output of 2.2kW per string for the SSB2512 or 2.9kW per string for the SSB2509. It is designed to handle a total of 108 amperes string current.

The Solstice SSB unit uses DC/DC converters to provide the inverter with 575VDC input voltage. The SSB unit monitors each individual string current, as well as temperature in two locations (one within the SSB enclosure and in one external user-defined location). The SSB unit also performs MPPT processing. All data is transmitted to the inverter through EIA-485 communications. Optional power line carrier communications eliminates the need for communication cabling.

The communication circuit board and all power electronics is contained in a weather-protected enclosure that meets IP66 standards. Finned aluminum heat exchangers are attached to the back of the unit for cooling purposes.

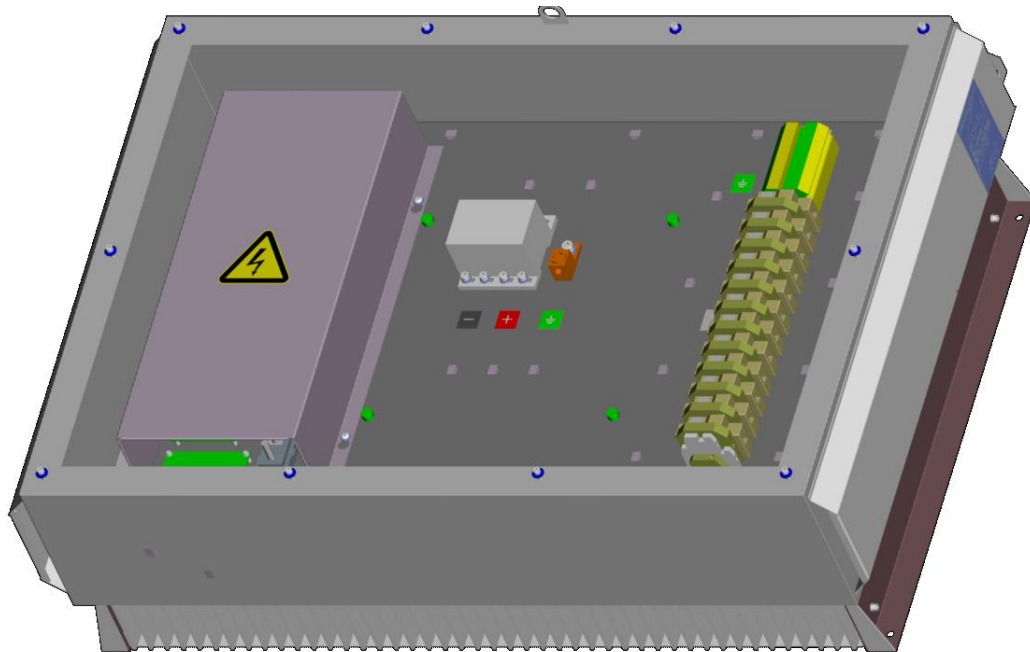

Figure 2 Solstice SSB Unit

Ratings and Specifications

Table 1 Ratings and Specifications for Solstice SSB (Sheet 1 of 2)

ELECTRICAL	SSB2512LNU	SSB2509LNU
Input		
Max number of strings	12	9
Voltage range, full power	300 – 575 VDC*	300 – 575 VDC*
Voltage range, MPPT	50 – 600 VDC**	50 – 600 VDC**
Max string current per channel	9 ADC	12 ADC
Output		
Rated DC Power	2200 W per string	2900 W per string
Max DC voltage	600 V	600 V
Max total DC output current	46 A	46 A
Max DC output current per channel	3.8 A	5.0 A
Max fuse size	16 A	20 A
EXTERNAL CONNECTIONS††		
DC output	35 – 185 mm ² (No. 2 AWG – 350 KCML), Ground: 50 – 70 mm ² (No. 1 – 2/0 AWG)	
String connection	4 – 16 mm ² (No. 10 – No. 6 AWG)	
String ground connection	2 – 4 mm ² (No. 14 – No. 12 AWG)	
Temperature sensor leads	0.10 – 4 mm ² (No. 26 – No. 10 AWG)	
Recommended temperature sensor cable	Belden P/N: 9341	
Recommended temperature sensor	Epcos P/N: B57703M0103G040	
Recommended signal cable (EIA-485)	USE-2 No.18 AWG, 2 pair stranded, shielded PVC direct burial cable (or equivalent)***† or Belden 1048 for conduit wires	
DIMENSIONS		
Width x Height x Depth	1013 x 760 x 345 mm (40 " x 30" x 13.6")	
Weight (approx.)	120 kg (265 lbs)	
INTERFACES		
Communication	EIA-485, 9600 baud, half duplex (Power Line Carrier Optional)	
Monitored input string current	TBD	
Monitored internal temperature	-20 °C to 85 °C +/- 5%	
Monitored external temperature	-20 °C to 85 °C +/- 5%	
STANDARDS		
CSA	Yes	
UL	1741	
Notes: *Full power is available down to 250 V at reduced ambient temperature **180 VDC minimum input to start MPPT operation ***Satcon recommends Belden P/N 1048A †Total length of network to be within 600 m (2000 ft) ††Application specific conductor sizing is the responsibility of the system installer		

Table 1 Ratings and Specifications for Solstice SSB (Sheet 2 of 2)

ENCLOSURE	
Outdoor installation	Yes
UV resistance	Yes
Material	Steel, G90 Pre-plated 1.5 mm
Color	RAL 7032
IPC protection	IP66
Type	NEMA 4
Operating ambient temperature range	-20 °C to 55 °C
Storage temperature range	-40 °C to 85 °C
Mounting Hardware required	Customer supplied 8 mm (3/8") bolt and nut
Notes: * Full power is available down to 250 V at reduced ambient temperature ** 180 VDC minimum input to start MPPT operation *** Satcon recommends Belden P/N 1048A † Total length of network to be within 600 m (2000 ft) †† Application specific conductor sizing is the responsibility of the system installer	

Chapter 2 Installation Information

About this Chapter

This chapter explains how to mount the Solstice SSB unit and install the wiring. The primary steps are:

1. Plan and install conduits
2. Mount the enclosure
3. Complete electrical connections

Step 1 – Plan and Install Conduits

All cables must enter and exit from the bottom of the Solstice SSB enclosure. Cables must pass through appropriately sized conduits or liquid tight, cord grip type, sealing glands.

Conduit Penetrations

It is advisable that conduit penetrations be made using either a hydraulic punch set or manual knockout punch tool. Knockout tools and punches are preferred to using a hole - saw as they produce no metal shavings that could cause short circuits or damage to components.

How and where conduits are installed depends on the final system configuration (and on the planned routing of the cables and wires). Due to this dependency, the installer is responsible for procuring the proper conduits and installing them where needed.

Ratings and Specifications

Table 1 provides the wiring and cabling data you will need to determine conduit sizes. In addition, you must consult the appropriate handbooks and local codes to ensure code compliance. The maximum conduit size is 53 mm (2 "). NEMA 4 (IP66) conduit connectors or cable glands **MUST BE** used to maintain the NEMA 4 rating. A typical installation uses one 2" liquid tight conduit fitting, Superflex P/N 88412 and three liquid tight cordgrips, Heyco P/N M4524GBM-SM, as shown in Figure 4.

Use the following information as a guide for proper conduit installation. The proper location for gland/conduit connectors can be found in Figure 3.

Enclosure Wall Thickness

The Solstice SSB unit uses 1.5 mm G90 steel (galvanized plated steel).

Preferred Practices

You can use either a hydraulic knockout punch tool or a manual knockout punch to create the conduit openings in this procedure. To install conduits (maximum conduit trade size 53 mm (2")):

1. Remove the glands before punching out the conduit openings.
2. Keep all sealing washers and fasteners for later reuse.
3. Drill a pilot hole in the required location in the gland.



CAUTION

Do not use hole-saws to make the opening in the next step because the resultant metal particles may cause faults that are beyond the scope of the warranty coverage.

4. Use either a hydraulic punch set or knockout punch tool to make the opening.
5. Install conduits.
6. Replace glands using the fasteners removed in Step 2.

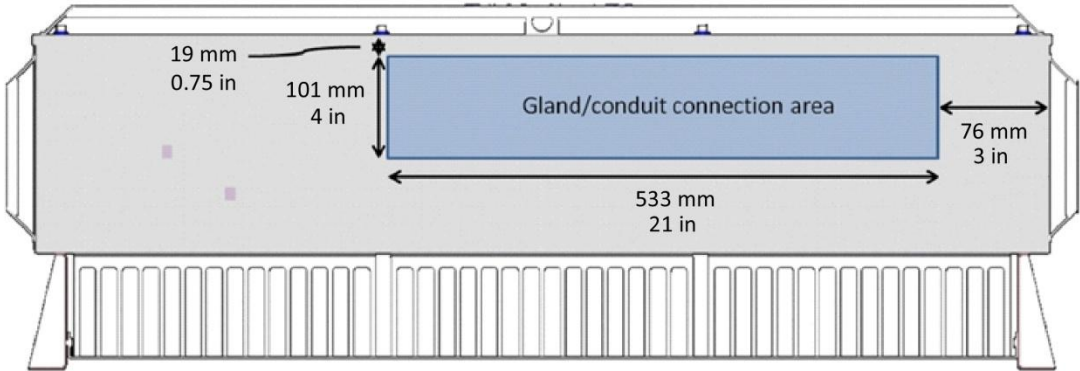

Figure 3 SSB Bottom View

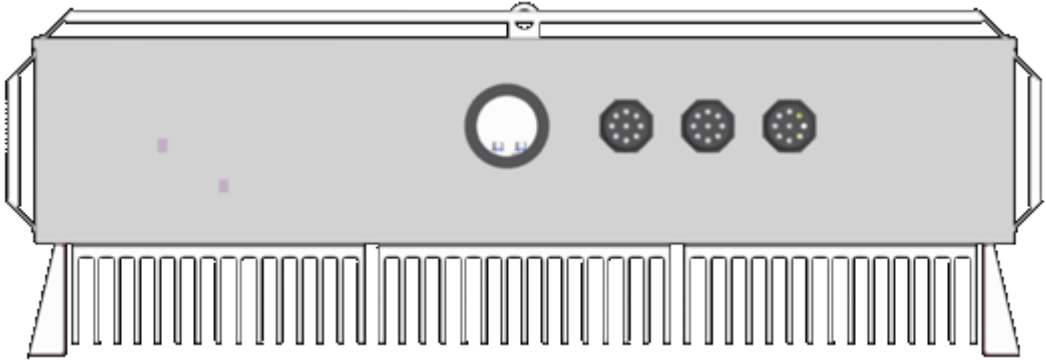

Figure 4 Typical Conduit Connections

Step 2 – Mount Enclosure



CAUTION – Heavy Equipment

The Solstice SSB enclosure weighs approximately 120kg (265 lbs).



CAUTION – Equipment Damage

Be sure to observe all local codes and standards for wiring and installation to prevent damage to the equipment.



NOTE

The through holes of the Solstice SSB enclosure are not threaded and mating nuts are required.

The Solstice SSB unit must be mounted vertically. The unit is mounted via holes in each corner (thru-hole for M8 or 3/8" fasteners). Refer to Figure 5 (for dimensions) and Figure 6 (for mounting pattern). Be sure that the mounting structure is strong enough to support the weight of the SSB unit.

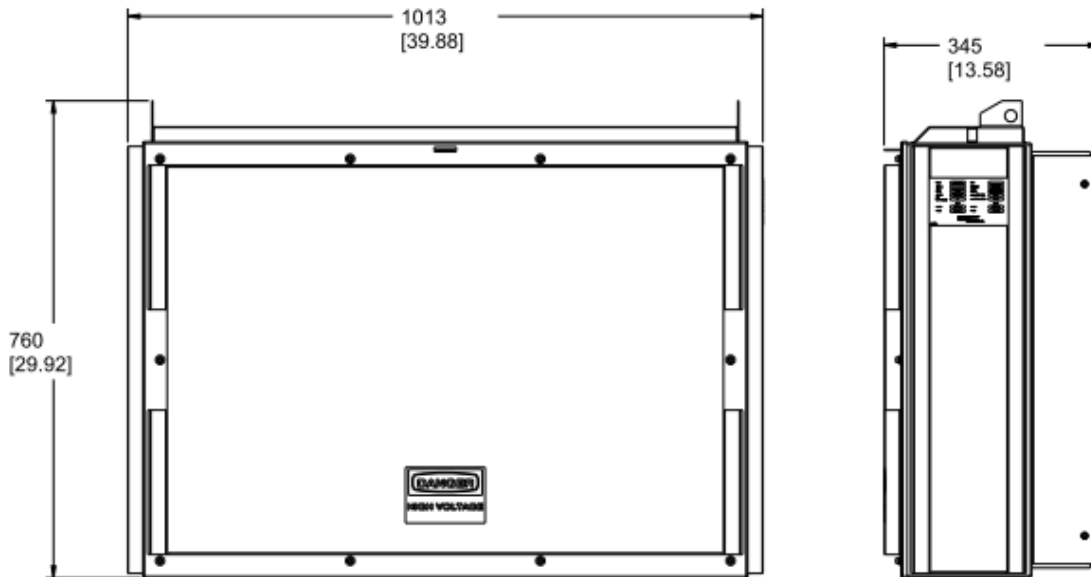
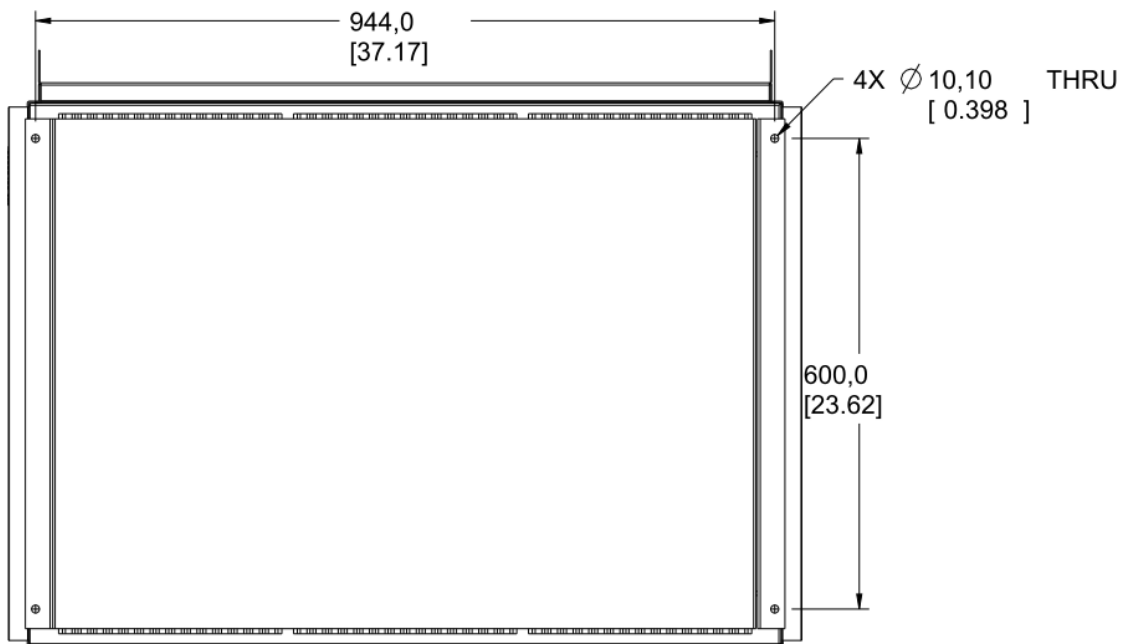
Figure 5 Solstice SSB Dimensions

Figure 6 Solstice SSB Mounting Diagram

Step 3 – Connect Electrical Conductors



WARNING

Make sure that the Solstice SSB unit is disconnected from the PV voltage source before any servicing or commissioning is done in this box. Before starting any work, check to be sure that no voltage is present in the box. Also, check to be sure that the unit cannot be reenergized. Observe proper lockout and tagout procedures.



CAUTION – Equipment Damage

Be sure to observe all local codes and standards for wiring to prevent damage to the equipment.

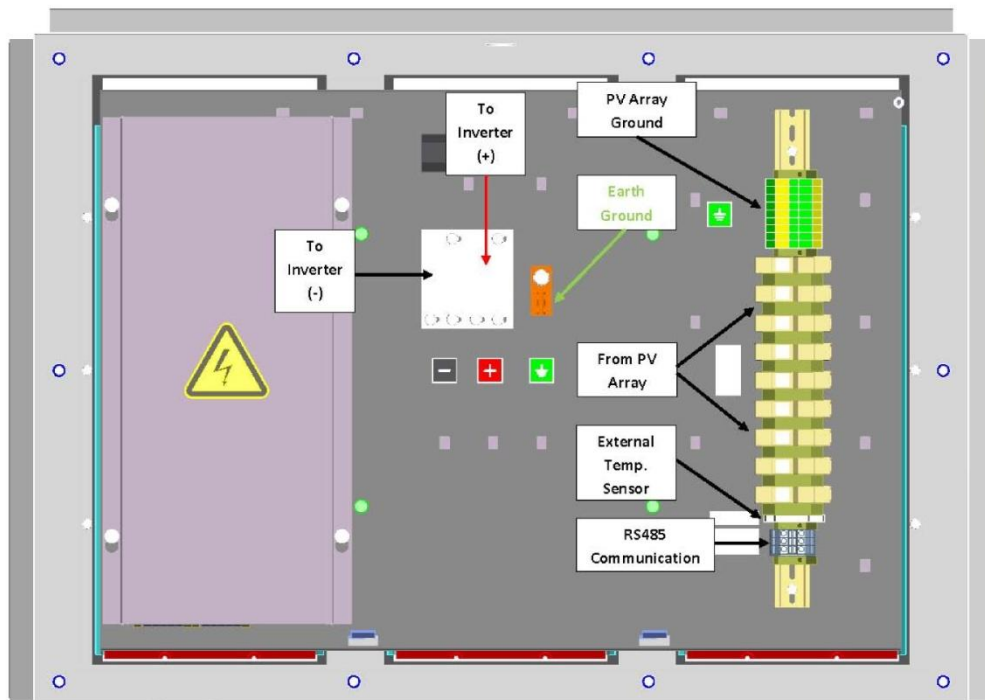

Figure 7 Customer Wiring Diagram

Use the following procedure to perform electrical connections.

1. Remove all DC string fuses from the fuse holders (12 fuses total for SSB2512LNU, 9 fuses total for SSB2509LNU).



WARNING

Do not put the fuses back in until all connections are made.

2. Test the continuity of all the DC fuses with an ohmmeter.
3. Attach a ground conductor to the earth ground lug provided. Torque ground bus connection to 14 – 17 Nm (125 – 150 in-lbs)
4. Install the ground wiring from array to the Earth Ground connectors. DC cables can be up to 16 mm² wire (No. 6 AWG). Torque connections no more than 1.5 Nm (13 in-lbs).
5. Install the wiring from each string to the fuse holders, terminal blocks and bus bar paying close attention not to mix the polarity of each string. Be sure to follow this sequence:
 - a. Install the first positive conductor in the fuse block;
 - b. Install the first negative conductor (feed the conductor through the cable pass through and connect to lower fuse holder rail;
 - c. Repeat steps 5.a. and 5.b. in that order for the remaining conductors.
6. Torque all connections to no more than 1.5 Nm (13 in-lbs).
7. Attach positive and negative wires from PV inverter to the terminal blocks and connect the earth ground wire. Cables can be up to 250 kcmil. Torque connections in the terminal blocks as shown in Table 2.

Table 2 Torque Ratings

Wire Size	Required Torque
130 – 95 mm ² (250 kcmil – 3/0)	22.6 Nm (200 in-lbs)
70 – 50 mm ² (2/0 – No. 1 AWG)	11.4 Nm (100 in-lbs)
35 mm ² (No. 2 AWG)	9 Nm (80 in-lbs)

8. **Optional** - Connect temperature sensors to on board connectors and mount in desired location. Satcon recommends using an EPCOS NTC thermistor P/N B57703M0103G040 for the temperature sensor and No. 18 AWG, 1 pair stranded, shielded PVC direct burial cable, Belden P/N 9341.
9. Connect the EIA-485 cables to block provided on TB1. See Single Line Diagram in Appendix for TB1 location. See Table 1 for cable recommendations.
10. Test all wiring to ensure correct polarity and sequence.
11. Install DC zone fuses removed in step 1 into the fuse holders.

Appendix

This appendix contains the following drawings:

Single Line Drawings

- SD00210 (SSB2512LNU)
- SD00214 (SSB2509LNU)

Enclosure Layout Drawing

- EL00532

SD00210 SHT. 1/1

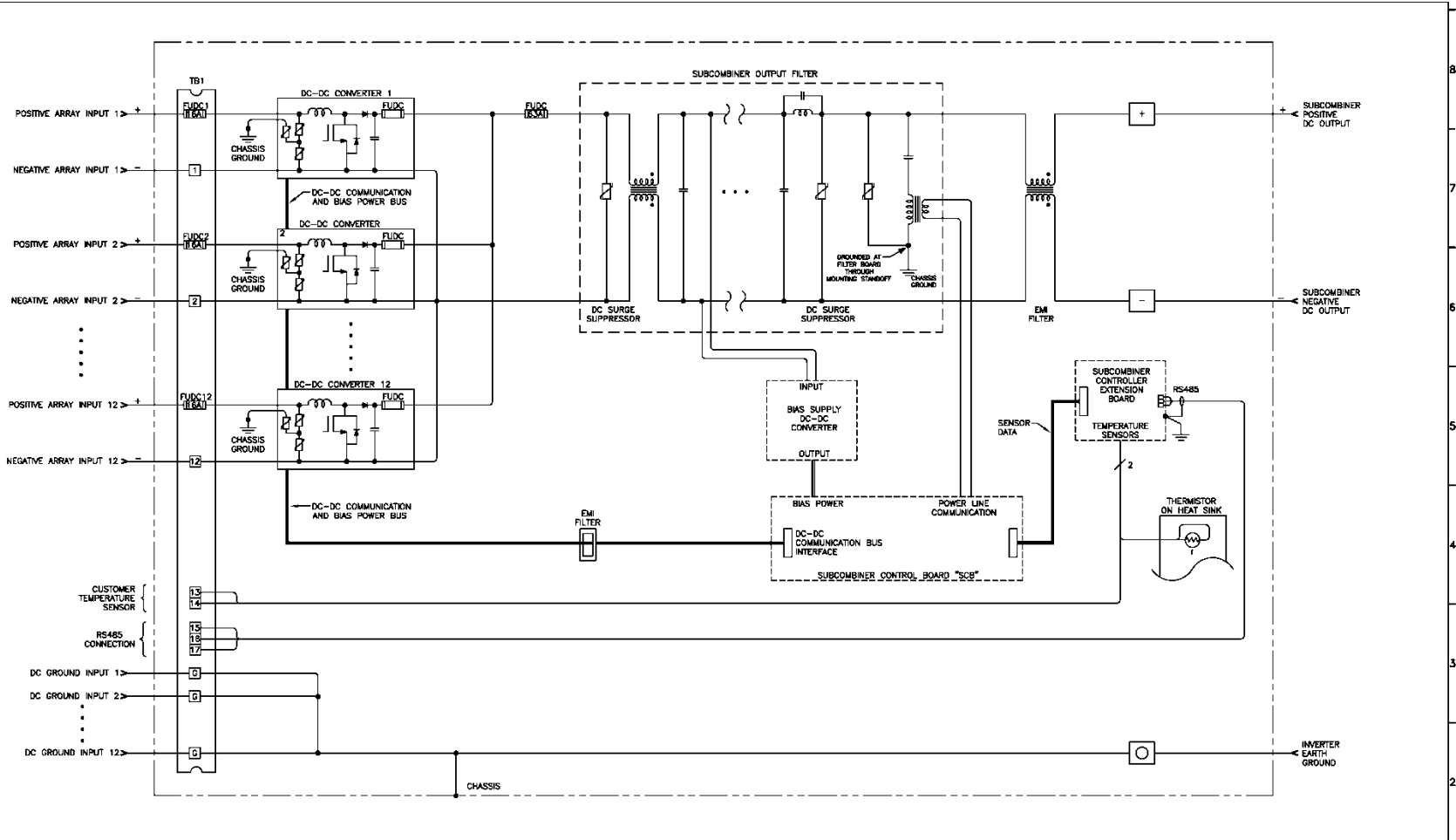

NOTES:
1. ALL GROUND TERMINAL BLOCKS ARE CONNECTED TO THE DIN RAIL.

REV	DESCRIPTION	DATE	DESIGN	DATE	APP'D	REV	DESCRIPTION	DATE	DESIGN	DATE	APP'D
4	ECD #10026	06/15/10	JL	GH	SN	1	DESCRIPTION	11/16/09	JM	SN	11/17/09
3	ECD #9557	03/30/10	JL	GH	SN	2	DESCRIPTION	11/16/09	JM	SN	11/17/09
2	ECD #9636	01/29/10	JL	GH	SN	3	DESCRIPTION	11/16/09	JM	SN	11/17/09
1	ECD #9585	01/14/10	JL	GH	SN	4	DESCRIPTION	11/16/09	JM	SN	11/17/09

4	ECD #10026	06/15/10	JL	GH	SN
3	ECD #9557	03/30/10	JL	GH	SN
2	ECD #9636	01/29/10	JL	GH	SN
1	ECD #9585	01/14/10	JL	GH	SN

4	ECD #10026	06/15/10	JL	GH	SN
3	ECD #9557	03/30/10	JL	GH	SN
2	ECD #9636	01/29/10	JL	GH	SN
1	ECD #9585	01/14/10	JL	GH	SN

4	ECD #10026	06/15/10	JL	GH	SN
3	ECD #9557	03/30/10	JL	GH	SN
2	ECD #9636	01/29/10	JL	GH	SN
1	ECD #9585	01/14/10	JL	GH	SN

THIS DRAWING IS CONFIDENTIAL AND PROPRIETARY INFORMATION OF SATCON POWER SYSTEMS CANADA LTD. ("SATCON") AND MUST NOT BE REPRODUCED OR TRANSMITTED IN ANY MANNER, DIRECTLY OR INDIRECTLY, IN ANY WAY DETRIMENTAL TO SATCON'S INTERESTS.

SD00214 SHT. 1/1

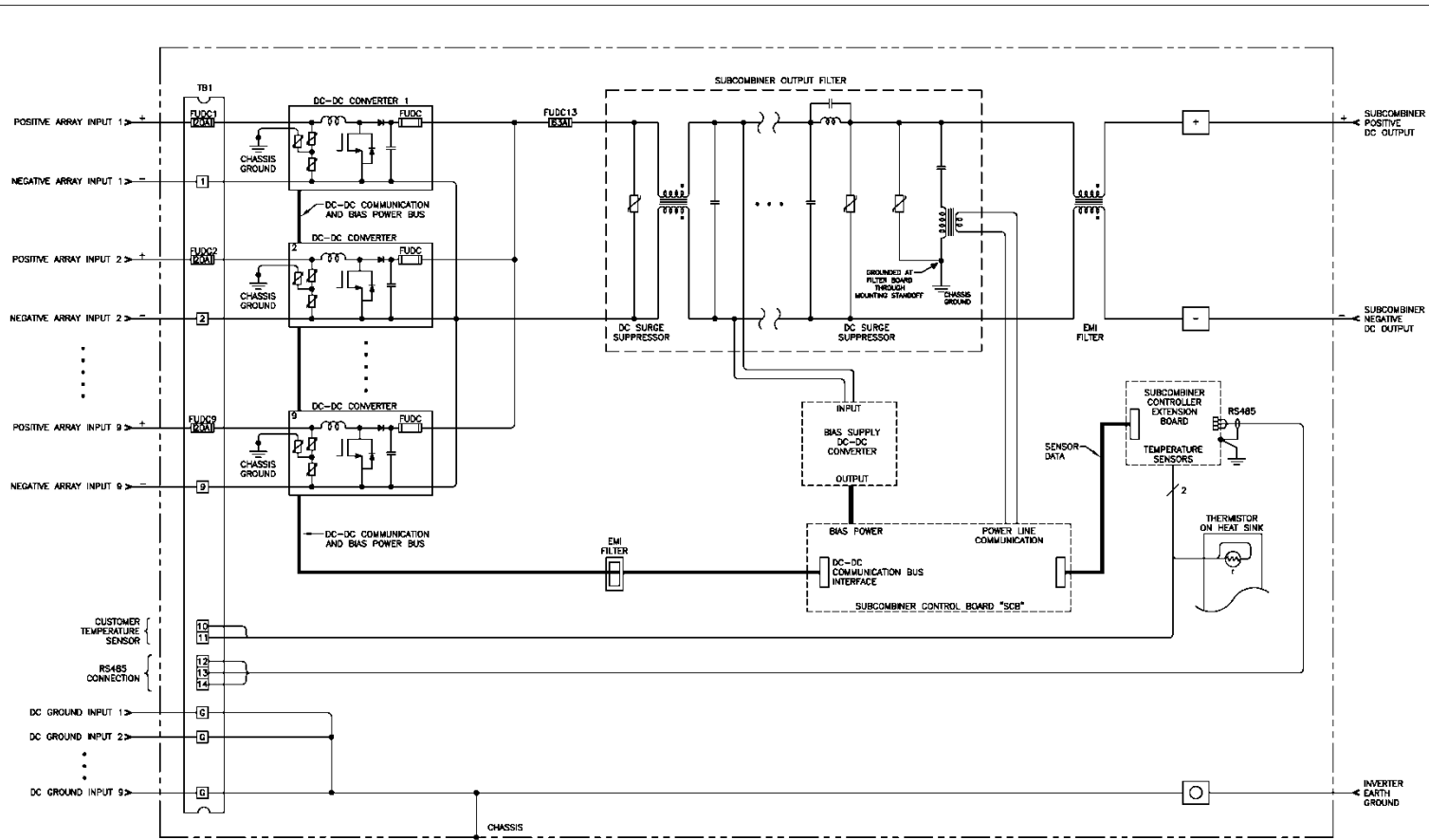

- NOTES:
1. ALL GROUND TERMINAL BLOCKS ARE CONNECTED TO THE DIN RAIL.

THIS IS AN ILLUSTRATION		REF:	
		Satcon Technology Corporation 37 English Avenue • Satcon MA 02218 USA Phone: (617) 887-2400 fax: (617) 887-2402 Web: www.satcon.com	
DATE CHANGED: 06/15/10 CHANGED BY: J.L. GH. SN REASON: 1. 11mm LOW PROFILE - 10.2mm		TITLE: SOLSTICE SUBCOMBINER SSB2509LNU DESCRIPTION: SINGLE LINE DIAGRAM	
REV	DESCRIPTION	DATE	DRWN
1	ECD #9868	06/15/10	J.L. GH. SN
APP'D	DATE	CHK'D	APP'D
GH	03/17/10	GH	GH
APP'Y	SN	03/17/10	
SCALE	N.T.S.	REV. 005	REV. 1

THIS DRAWING IS CONFIDENTIAL AND PROPRIETARY INFORMATION OF SATCON POWER SYSTEMS CANADA LTD. ("SATCON") AND MUST NOT BE REPRODUCED OR TRANSMITTED IN ANY MANNER, DIRECTLY OR INDIRECTLY, IN ANY WAY DETRIMENTAL TO SATCON'S INTERESTS.

Appendix

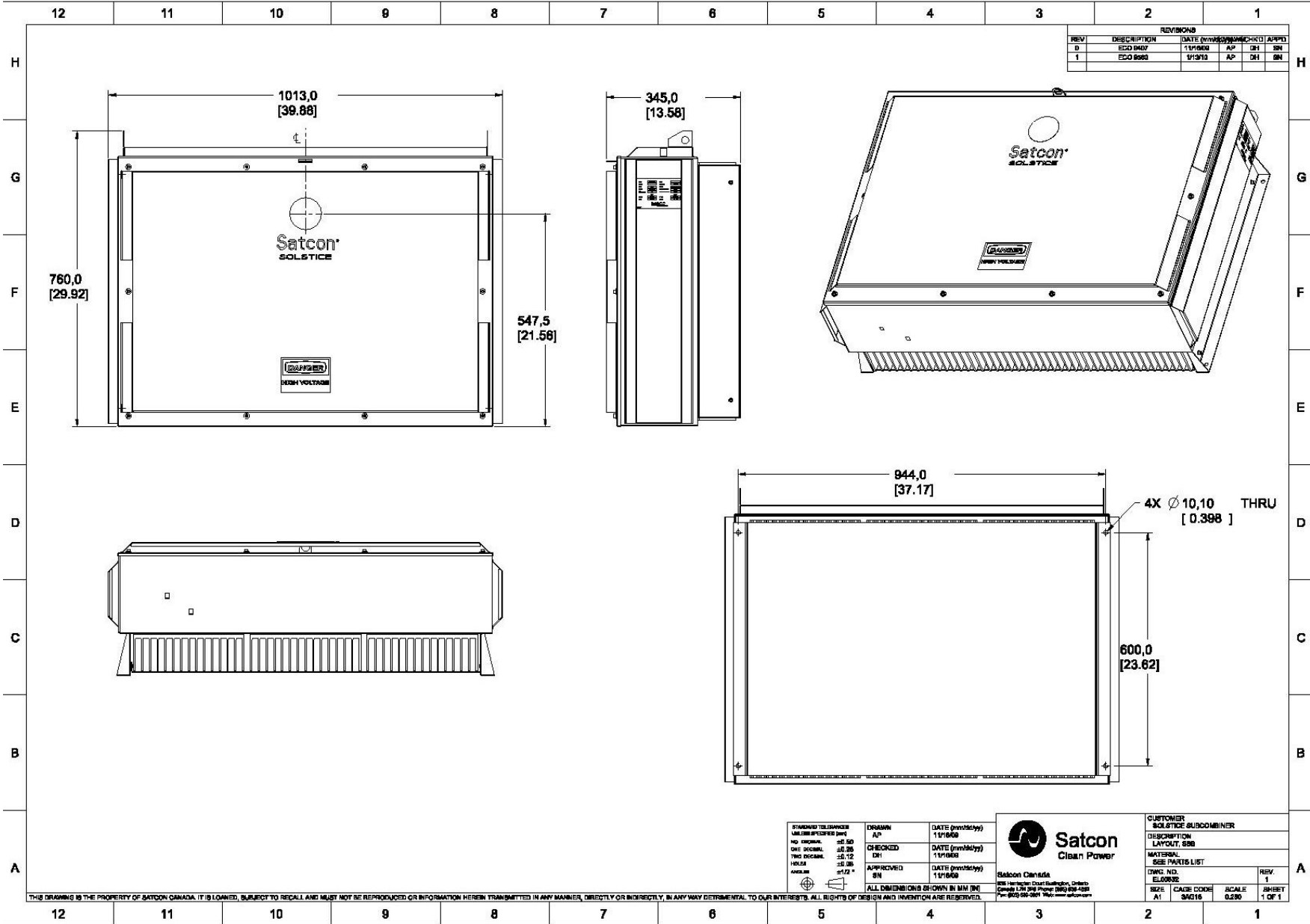

THIS PAGE INTENTIONALLY LEFT BLANK



Satcon Technology Corporation

27 Drydock Avenue, Boston, MA 02210, U.S.A.
Tel: 617.897.2400 | Fax: 617.897.2401 | www.satcon.com